



Simply Firmly Closely. Connected

IDEAL-MAXI-Hose Clamps



also available
with hex socket



IDEAL-MAXI-Hose Clamps

Connection technology. Robust and reliable.

The particularly robust IDEAL-MAXI-Hose Clamp is suitable for the most challenging of situations and for the transmission of high clamping force levels.

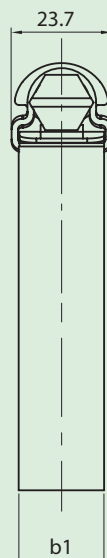
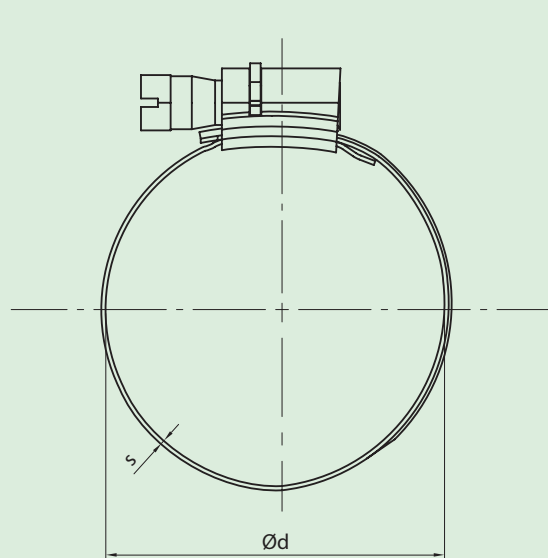

20 mm bandwidth

- Robust applications
- Greatest torque application: 18 Nm
- Wide clamping ranges
- Easy to use
- Diameter from 60 mm upwards
- Customer requirements determine maximum diameter

Example for ordering IDEAL-MAXI-Hose Clamp

Article no: **W1 20 M08**

Material quality

Band width (b1)

Clamp range (d max)

Material qualities

W1

Band	Shiny galvanised steel
Casing	Shiny galvanised steel
Screw	Shiny galvanised steel, blue passivate
Screw head type	Slotted hex head screw SW 13 mm

All parts are made with shiny galvanised steel. Low-level corrosion resistance. Cr (VI) free.

W5

Band	Chrome nickel steel, material 1.4305
Casing	Chrome nickel steel, material 1.4305
Screw	Chrome nickel steel, material 1.44
Screw head type	Slotted hex head screw SW 13 mm

All parts are made with shiny chrome nickel molybdenum steel (1.4401), also known as V4A. Highest level of corrosion resistance (resistant to sea water). Highly magnetisable.

Clamping ranges

Type	Clamping range from (d min)	to (d max)
M05	60 mm	80 mm
M06	70 mm	90 mm
M07	90 mm	120 mm
M08	105 mm	130 mm
M09	122 mm	157 mm
M10	142 mm	177 mm
M11	167 mm	202 mm
M12	192 mm	227 mm
M13	217 mm	252 mm
M14	242 mm	277 mm
M15	267 mm	302 mm
M16	292 mm	327 mm

Band dimensions

Casing: band thickness 1.50 mm

The 1.5 mm thick steel band for the IDEAL-MAXI-Hose Clamp allows for the secure connection of screw and band and therefore for the transmission of high force levels. The highest rupture torques, therefore, are achieved at low idling torques. Combined with the comparably low-level friction and the worm-drive, this results in high clamping force levels.

Thread tapes: band thickness 1.00 mm

The 1.00 mm thick band allows for the transmission of top clamping force levels that are derived from the particularly stable design of the engraved band thread (specifically designed for the special screw thread). At the same time, these materials ensure a high level of elasticity and a strong, positive connection with the external diameter of the hose.

PU/packaging material

IDEAL-MAXI-Hose Clamps are available in the following packaging units:
From type M05 upwards: loose



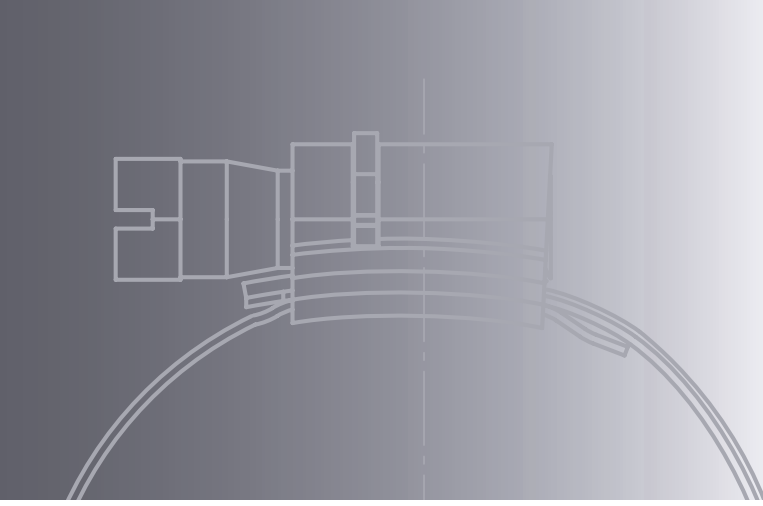

Other Products

IDEAL-Hose Clamps DIN 3017

9 mm band width:

- All standard applications
- High-level clamping force at narrow band width and low weight
- Compact design
- Tightly graduated diameter range from 8 mm
- Customer requirements determine max. diameter

12 mm band width:

- More sophisticated applications
- Stable connection with low-level surface pressure
- High clamping force
- Tightly graduated diameter range from 12 mm
- Customer requirements determine max. diameter

IDEAL-small

5 mm band width:

- Low height
- Space-saving assembly
- High-level of flexibility
- Diameter range from 7 mm
- Customer requirements determine max. diameter
- Advantage of a wider clamping range and can be adjusted and re-used

T-bolt clamps

- High clamping force for securing heavy, smooth hoses
- Easy and quick to fit
- Re-usable

Spring clamps

Spring clamps, spring-loaded:

- Material:
Round steel wire as per EN10270-1:2001
- Finish:
White zinc coating CrVI free as per RoHS standard

Spring clamps, screwed:

- Material:
Round steel wire as per EN10270-1:2001
- Finish:
White zinc coating CrVI free as per RoHS standard

Accessories

- Workshop range
- Screwdrivers

Special clamps

Applying our extensive experience, we adapt our hose clamps to suit your specific requirements.

Ligatech Befestigungstechnik

Schmidtenbaumgarten 10
8917 Oberlunkhofen

Telephone: 0041 (0) 56 640 30 00
Telefax: 0041 (0) 56 640 30 01

Email: info@ligatech.ch
Internet: www.ligatech.ch

